



General Information

General Information

HTM-930

Vibration Type Level Switch

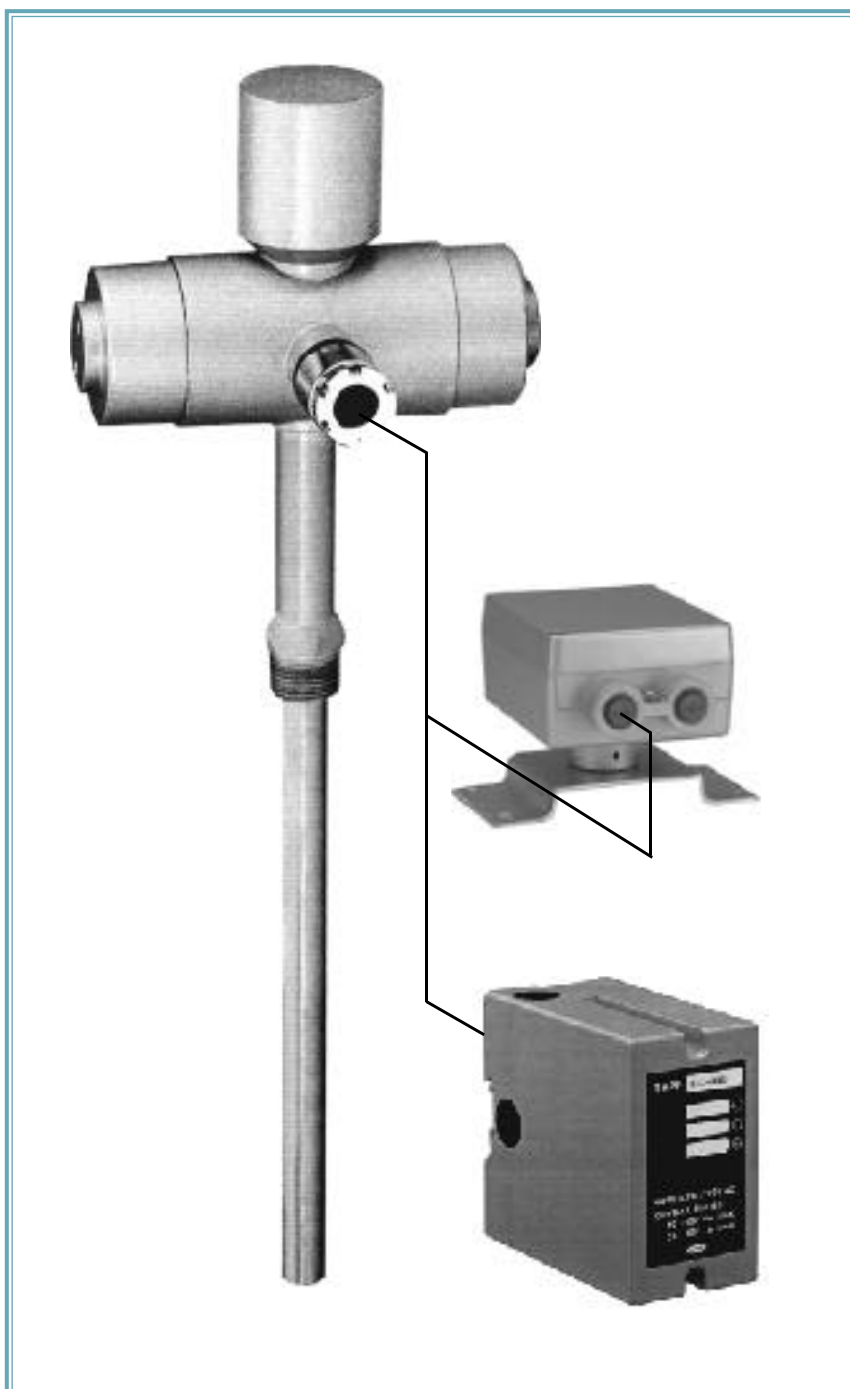

HITROL CO., LTD.

Features

- * Can detect level of various solids and powders
- * Can be fully operated for powders of low and high densities.
- * Can detect the interface of sediments in the liquid.
- * Has a longer lifetime since it has no mechanical movements.
- * Does not need adjustments after installation.

Specifications

Body	Steel (SS41)
Protection	IP65
Range of Environment Temp.	-20 ~ + 60
Mounting Material	Stainless Steel (SUS 304)
Mounting Specification	3/4 "PT (KSB0222)
Operating Temp.(Inside Vessel)	-20 ~ + 250
Max. Pressure	10 kgf/cm ²
Combination Unit	HLC-901
Power Supply	AC 110 V / 220 V 60 Hz ± 10 %
Power Consumption	Approx. 5 VA
Sensitivity	Over 0.2(Specific Gravity)
Relay Output	Max. AC 250 V, 5 A
	Max. DC 28 V, 5 A
	(Relay 1 SPDT)
Indication of Switch	When relay is on.
	When detection LED is off.
	When detection LED becomes RED.
Painting	Metallic silver
Distance Between Sensor and unit	Max. 300 m
Cable	twisted paired cable

Operating Principle

HITROL's HTM is an innovative, multi-purpose switch and has the simplest structure.

HTM sensor head is composed of one module which has an oscillating coil generating frequency and a sensing coil detecting oscillation.

When the material inside the vessel does not exist around the sensing rod, the sensing rod continuously vibrates due

to the oscillating coil.

When the material inside the vessel exists around the sensing rod, the vibration frequency is significantly reduced, and the output from the sensing coil is decreased to a very low value.

It is operated using the above mentioned operation principle, and when a signal is supplied to alarm and/or process control.

(Converter)

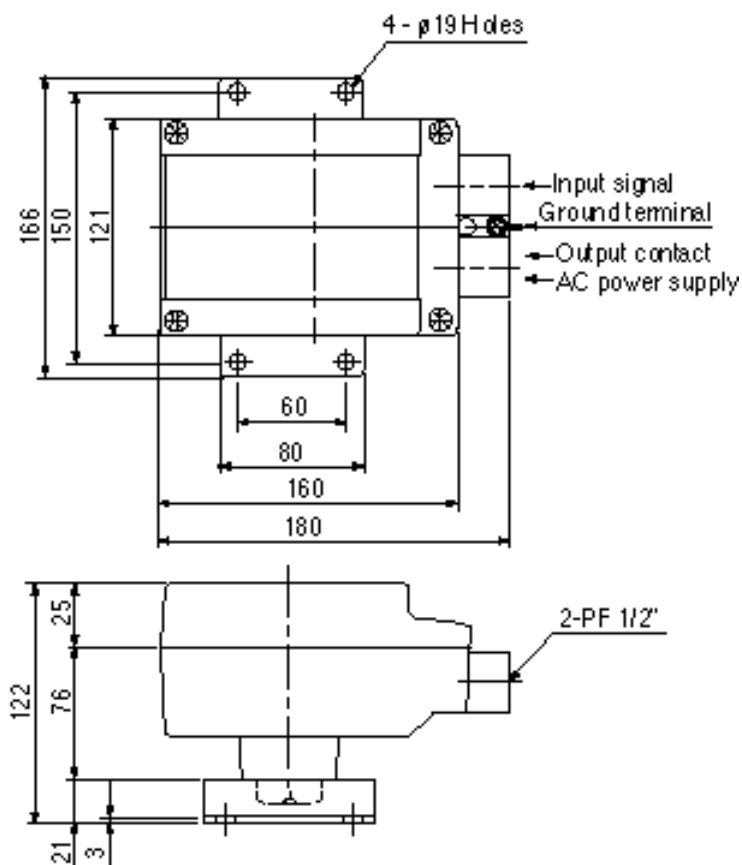

Dimensions

(Sensor)

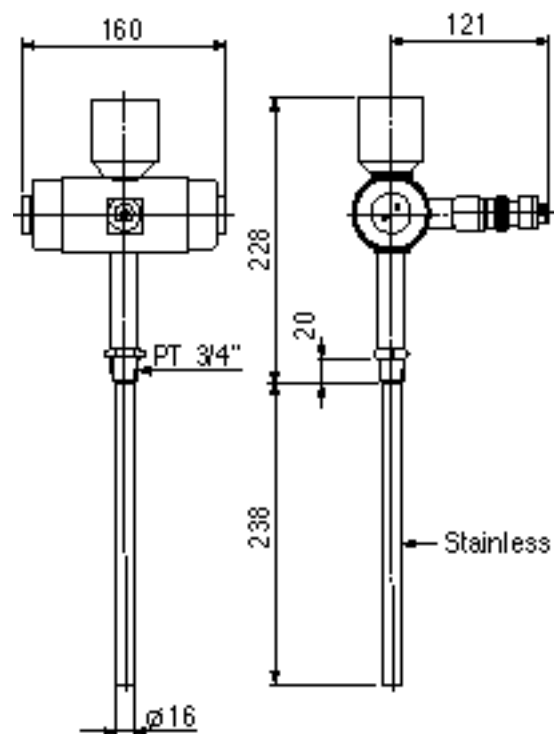

1. Sensor should be installed using a 3/4 "PT coupling or a designated flange.
2. Sensor should not be installed at the inlet of material to be measured.
(However, when sensor is installed at the inlet of material to be measured, the protection plate for the sensing rod should be installed to endure the force due to falling of material to be measured. Refer Fig. 1.)
3. The direction of cable gland should be forwarded to the ground.

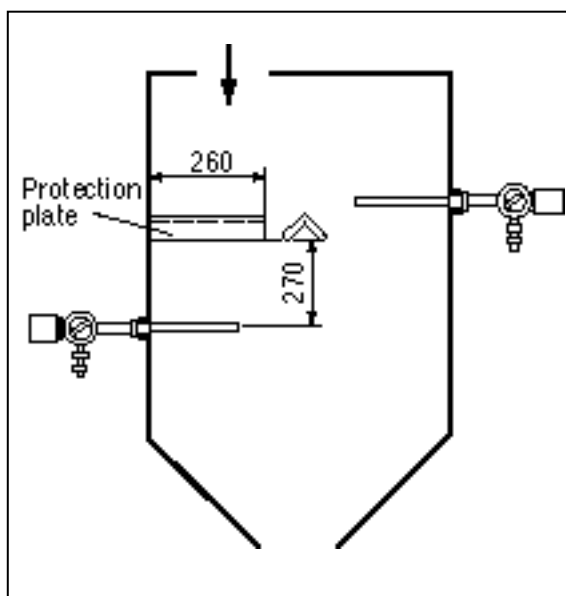

Fig. 1 Schematic diagram for installation

Installation Method

Wiring Method

1. Refer Fig. 2.
2. Two-wire twisted shield cable should be used when wiring sensor and the unit. (HITROL's standard length is 6 m. However, when the distance between the sensor and the unit is over 6 m, it is required to consult cable specification to HITROL.)
3. When wiring between the sensor and the unit, the separate cable conduits should be used for power and sensor signal.
4. It should be grounded for either the sensor or the units.

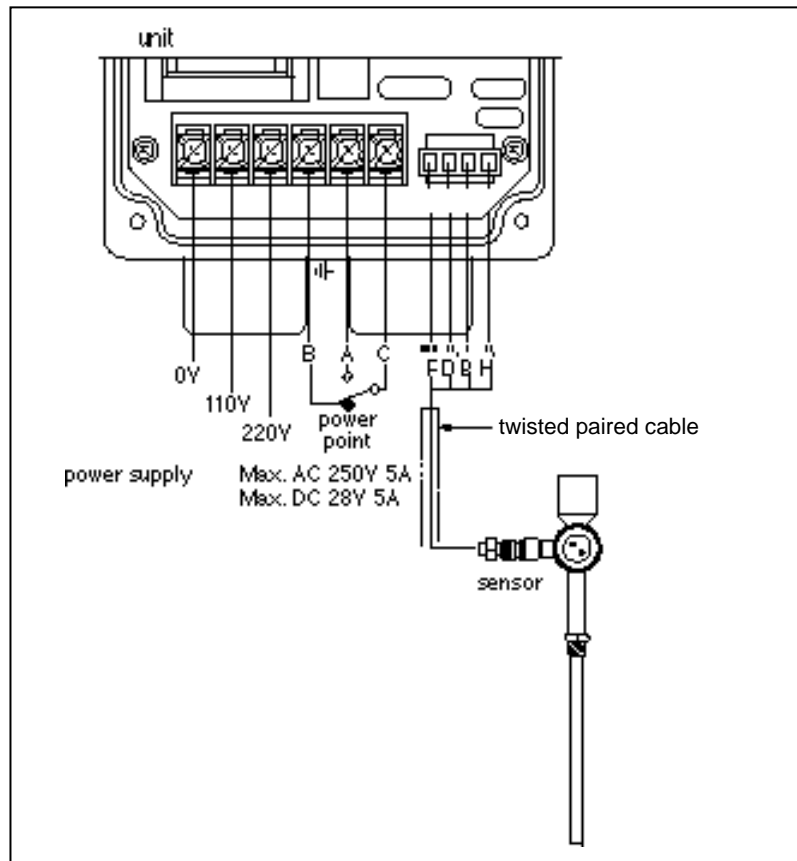

Fig. 2 Schematic diagram for wiring

Maintenance

It is recommended to clean and check the sensing rod frequently by removing the sensing rod from the vessel when the material is hard or viscous.

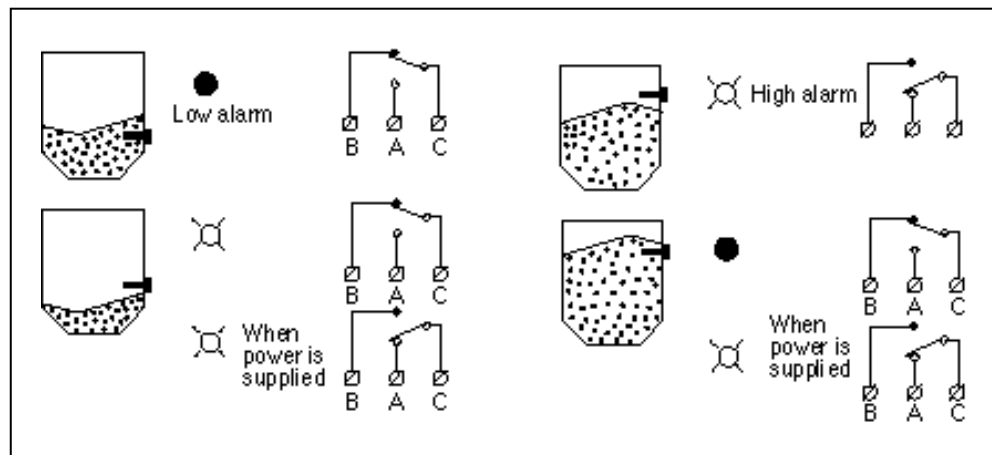

Fig. 3 LED and operation of contact point

HITROL **HITROL CO., LTD.**

HEAD OFFICE · FACTORY · R & D INSTITUTE
62-182 BONGILCHEON-RI CHORI-MYUN
PAJU CITY KYUNGGI-DO KOREA
TEL : (031) 943-0875~7
FAX : (031) 943-0878, 5600
<http://www.hitrol.co.kr> hitrol@hitrol.co.kr